

## 仕様

屈折率	1.50
比重	1.28
アッペ数	57
設計	球面
小玉内寄	2 mm
加入度数	1.50~3.00

## 対応コート

- ハード
- ハードマルチ
- つるつる

## 製作範囲表

度数 (-)	球面	乱視 (-)															
		0.25	.50	.75	1.00	.25	.50	.75	2.00	.25	.50	.75	3.00	.25	.50	.75	4.00
0.00																	
.25																	
.50																	
.75																	
1.00																	
.25																	
.50																	
.75																	
2.00																	
.25																	
.50																	
.75																	
3.00																	
.25																	
.50																	
.75																	
4.00																	
.25																	
.50																	
.75																	
5.00																	
.25																	
.50																	
.75																	
6.00																	

度数 (+)	球面	乱視 (+)															
		0.25	.50	.75	1.00	.25	.50	.75	2.00	.25	.50	.75	3.00	.25	.50	.75	4.00
0.00																	
.25																	
.50																	
.75																	
1.00																	
.25																	
.50																	
.75																	
2.00																	
.25																	
.50																	
.75																	
3.00																	
.25																	
.50																	
.75																	
4.00																	

C(-)	混合乱視 (MIX)											
	S(+)	.50	.75	1.00	.25	.50	.75	2.00	.25	.50	.75	3.00
0.25												
.50												
.75												
1.00												
.25												
.50												
.75												
2.00												
.25												
.50												
.75												
3.00												

最小濃度  
約5%

ブラウン

最大濃度  
約80%  
(気温23°Cの場合)



※使用環境（気温・紫外線量等）により、調光濃度や調光スピードが異なります。

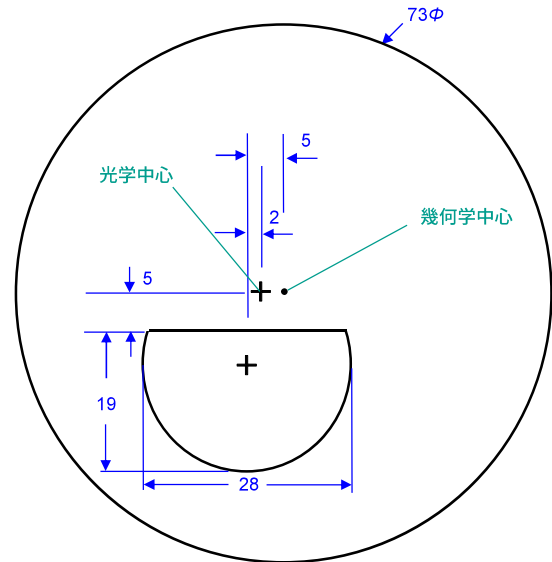

## 特殊加工

外径指定	○	※1
プリズム	○	※2
偏心	×	
カーブ指定	×	
UVカット	標準	※3
厚み指定	○	
玉型カット	○	
スライス加工	×	

原産国

日本

※1 [縮小]  
(+, MIX範囲) 基準径~最小55mm (1mm単位)  
[拡大]  
可表記まで製作可 (1mm単位)

※2 (-) S+C=-2.00まで 3△まで可  
(-) S+C=-2.50まで 2△まで可  
(-) S+C=-5.50まで 1△まで可  
(+) S+C=+2.00まで 3△まで可  
(+) S+C=+3.00まで 2△まで可  
(+) S+C=+4.00まで 1△まで可  
(MIX) C=-2.50まで 3△まで可  
(MIX) C=-3.00まで 2△まで可

※3 UV400